

AIR CONDITIONER ACM 18 CBRN

FUNCTION

The ACM 18 CBRN Air Conditioner is a transportable unit, developed primarily to provide air conditioning in temporary or transportable buildings or tents. It is a small light weight unit made out of aluminium and built into a rigid steel frame. The unit is designed to operate on COLPRO applications with the evaporator module placed inside the shelter and the condenser module placed outside. The two modules are interconnected by 5 m long refrigerant hoses, power and control cables. The interconnections are all equipped with quick disconnect components for quick and safe setup and take down. The HVAC unit can also operate with both modules placed outside, with supply air and return air ducted to one tent. A dual filtration system for the internal air path is available for selective filtration.

The function of the ACM 18 CBRN is based on a cooling circuit and two powerful fans. The evaporator section contains the evaporator and a radial fan, which draws warm internal air of the tent through the cold evaporator and blows out the cooled air either through the side or top of the unit. The condenser section contains two condenser coils and a large axial fan, returning the heat taken from the internal air to the outside atmosphere.

The ACM 18 CBRN can be equipped with an electric heating coil, to provide heating for example for night time when temperatures can fall under 20°C.

All sheet metal parts are protected against corrosion by a minimum 80µm top coat.



FEATURES

- The ACM 18 is built into a strong metal frame with insulated panels where relevant, powder coated.
- Top finish painting is standard sand colour
- Designed for air conditioning when the temperature is above 20°C. It can provide cooling at ambient temperatures up to +60°C Option with built in heating will heat when ambient temperature is below 20°C.
- Scroll compressor for a high degree of reliability and low noise level.
- Automatic phase surveillance
- Environment-friendly R134a refrigerant.
- HP/LP pressostat switches ensuring long compressor lifetime.
- Controlled by a room thermostat placed inside the tent (accessory)
- G3 filtration of the internal air
- Fresh air intake
- Dual filters in front of internal air intake as an option
- Four way fork lift handling.
- Easy strap down on air cargo pallets and stackable (two units on top of each other)
- Insulated flexible ducts Ø400 mm for air transport (accessory)
- Low voltage control
- CE-marked

ACCESSORIES

- Remote thermostat with 15 m cable and cooling/heating selector switch
- Insulated, flexible duct Ø400x3000 mm incl. storage bag
- Uninsulated, flexible duct Ø400x5000 mm incl. storage bag
- Air distribution duct Ø400x6000 mm
- F7 filter
- Trolley with wheels (more detailed description under "Accessories")

TECHNICAL DATA

Nato Stock Number w/o heat		4120-22-618-1245
Nato Stock Number with 6/16 kW heat and softstarter	NSN	4120-22-615-5383
Operating range, cooling	°C	20-60
Operating range, heating	°C	-32-(+20)
Airflow, internal, with ducts	m³/h	2500
Airflow, external	m³/h	5600
Cooling capacity*	kW/BTU	17,5/60000
Heating capacity optional	kW/BTU	16/20 / 55000/68000
Power supply	V/Hz	3x400 / 50
Max. running current (cooling/heating)	A	16 / (dependent on heating capacity)
Locked rotor amperage (LRA)**	A	101
Max. power consumption (cooling/heating)	W	8300
Refrigerant		R 134a
Refrigerant connection hoses stainless steel	m	5
Filter material	EN 779	G3 + optional
Protection class	IP	X5
Flex. air duct connection	Ømm	400
Noise level, 1,5 m distance	dB(A)	72
Weight (without accessories evap/cond)	kg	137/104

*Performance varies with varying conditions | **Soft starter available

UNIT COMPONENTS AND AIRFLOW

1	Condenser air intake
2	Condenser air discharge
3	Warm air intake
4	Dual filter system (optional)
5	Cooled air discharge
6	Duct coupling (Ø400 mm)
7	Electric panel w. cover

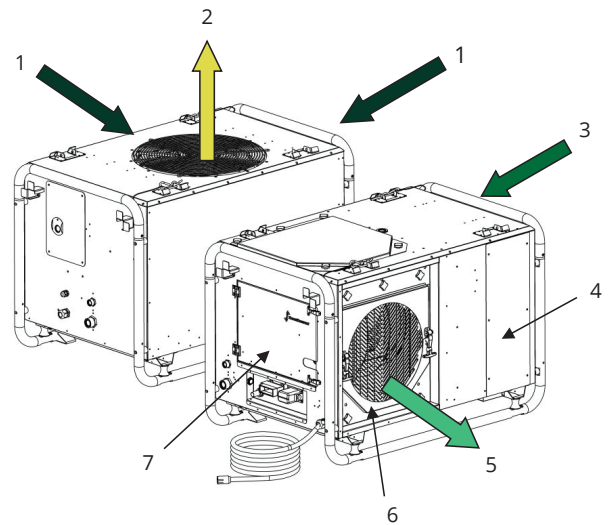

DIMENSIONS

