

AIR CONDITIONER ACM 18

FUNCTION

The ACM 18 Air Conditioner is a transportable unit, developed primarily to provide air conditioning in temporary or transportable buildings or tents. The unit is designed to be placed outside, with supply air and return air ducted to the tent. For field hospitals where a higher filtration than for normal accommodation is wanted, a dual filtration system for the internal air path is available.

The function of the ACM 18 is based on a cooling circuit and two powerful fans. The evaporator section contains the evaporator and a radial fan, which draws warm internal air of the tent through the cold evaporator and blows out the cooled air through the side or the top of the unit. The condenser section contains two condenser coils and a large axial fan, returning the heat taken from the internal air to the outside atmosphere.

The ACM 18 can be equipped with an electric heating coil, to provide heating for example for night time when temperatures can fall under 20°C.

All sheet metal parts are protected against corrosion by a minimum 80µm top coat.



FEATURES

- Designed for optimal utilisation of a standard 20" ISO container (24 pcs.)
- The ACM 18 is built into a strong metal frame with insulated panels where relevant, powder coated.
- Top finish painting is standard sand colour
- Designed for air conditioning when the temperature is above 20°C. It can provide cooling at ambient temperatures up to +60°C Option with built in heating will heat when ambient temperature is below 20°C.
- Scroll compressor for a high degree of reliability and low noise level.
- Automatic phase surveillance
- Environment-friendly R134a refrigerant.
- HP/LP pressostat switches ensuring long compressor lifetime.
- Controlled by a room thermostat placed inside the tent (accessory)
- G3 filtration of the internal air
- Fresh air intake
- Dual filters in front of internal air intake as an option
- Four-way fork lift handling.
- Easy strap down on-air cargo pallets and stackable (two units on top of each other)
- Insulated flexible ducts Ø400 mm for exhaust and return air openings
- Low voltage control circuit
- CE-marked

ACCESSORIES

- Remote thermostat with 15 m cable and cooling/heating selector switch
- Flexible ducting of various sizes
- Internal air distribution/plenum
- G3, G4, F7 filter options

TECHNICAL DATA

Nato Stock Number w/o heat	NSN	4120-22-615-5382
Nato Stock Number with 6/16 kW heat and soft starter	NSN	4120-22-616-8876
Operating range, cooling	°C	20-60
Operating range, heating	°C	-32-(+20)
Airflow, internal, with ducts	m ³ /h	2500
Airflow, external	m ³ /h	5600
Nominal Cooling capacity*	kW	17,5
Heating capacity optional	kW	6/16
Power supply	V/Hz	3x400 / 50
Max. running current (cooling/heating)	A	16 / 26
Locked rotor amperage (LRA)**	A	101
Power consumption (cooling/heating) tested	W	8300 / variable
Refrigerant / quantity	kg	R 134a / 7,8
Filter material	EN 779	G3 + optional
Protection class	IP	X5
Flex. air duct connection	Ømm	400
Noise level, aircon 3m distance, measured in shelter	dB(A)	59
Weight (without accessories), with heat	kg	240

*Performance varies with varying conditions | **Soft starter available

UNIT COMPONENTS AND AIRFLOW

- | | |
|---|-------------------------------|
| 1 | Condenser air intake |
| 2 | Condenser air discharge |
| 3 | Warm air intake |
| 4 | Dual filter system (optional) |
| 5 | Cooled air discharge |
| 6 | Duct coupling (Ø400 mm) |
| 7 | Electric panel w. cover |

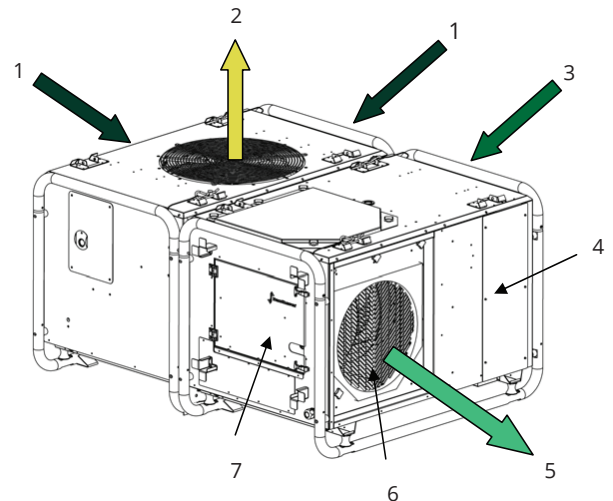

DIMENSIONS

